

MODEL 110S

Stepper Label Applicator



 auto labe

MODEL 110S

Stepper Label Applicator

The model 110S stepper drive label applicator with PLC control is designed for exceptional label placement accuracy and reliability in high speed applications. The model 110S is built with 24/7 operation in mind and can be deployed in the harshest environments. It can be used as a stand-alone wipe on and is also the base of our tamp and tamp blow-on label applicators. When integrated into product handling systems the Model 110S is the premier label applicator featured in our 600S series labeling system.

FEATURES:

- Stepper motor drive
- PLC control with SD card slot for upgrades
- Rates to 300ppm with +/- 1/32" accuracy at stripper plate
- Simple label teach function
- 5.7" HMI color touch screen with cable mount and USB port for upgrades
- User friendly screen menus
- Anti-static technology
- 60 programmable presets
- Heavy duty stainless steel components & a clear anodized aluminum body
- Simple label web path
- Password protect screen access (optional setting)
- Set maintenance and cleaning reminders
- Integrates with previous Auto Labe mounts and systems
- Multiple label drop settings
- Made in the USA

SPECIFICATIONS:

Speed:
Up to 1800" per minute

Web Width:
6.5"

Electric Requirements:
120 VAC 50/60 HZ/5 AMP
220 VAC 50/60 HZ/5 AMP

Equipment Weight:
33 lbs/15 kg (approx.)
46 lbs boxed

Equipment Dimensions:
30"L x 15"W x 28"H
(Applicator Only)

OPTIONS:

- Label widths 4.5" / 6.5" / 9.5"
- Web monitoring
- Connection to table top thermal printers
- Output monitoring port
- Warning towers
- Hot stamp date/lot coder
- Encoder (interface ready applicator)
- Adjustable heavy duty stand
- Upgrade to clear label sensor
- Conveyor systems for product handling

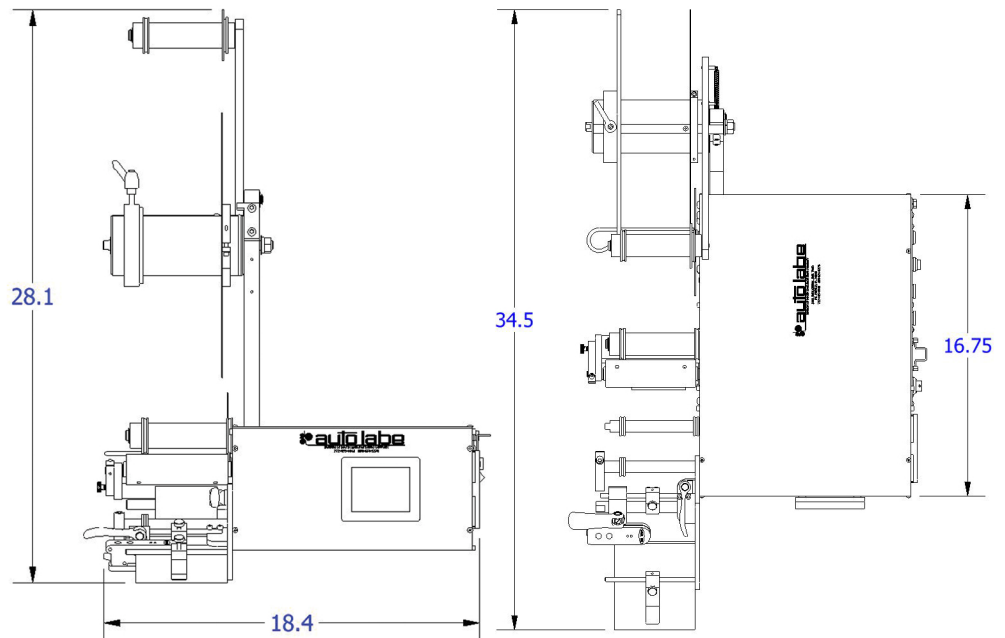

3101 Industrial Avenue Two, Fort Pierce, Florida 34946
Toll Free 800-634-5376 • 772-465-4441 • Fax 772-465-5177
www.autolabe.com • e-mail: info@autolabe.com